

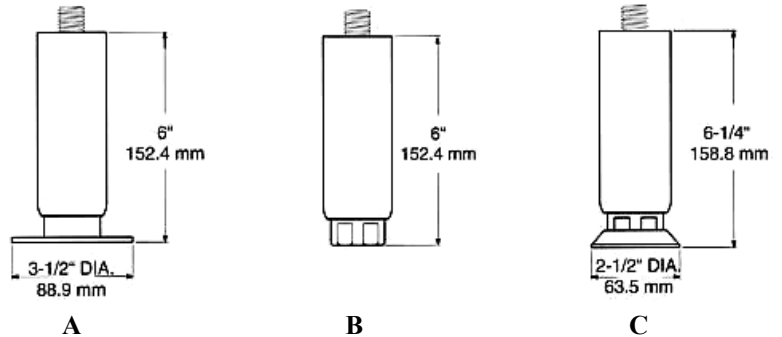

B.P 9168
 95075 CERGY PONTOISE CEDEX
 Tél : 01 34 48 34 10 / Fax : 01 34 21 80 40
 info@epcifrance.com
 www.epcifrance.com

PIEDS REGLABLES INOX

Série 1751



Ref.	Model n°	Mounting type	Toe type	Qty / carton
A	61751FF60T7	3/4"-10 Thru	Flanged	20
	61751FF60F7	3/4"-10 Flush	Flanged	20
B	61751HF60T7	3/4"-10 Thru	Hex	24
	61751HF60F7	3/4"-10 Flush	Hex	24
C	61751NG60T7	3/4"-10 Thru	Nylon guide	20
	61751NG60F7	3/4"-10 Flush	Nylon guide	20

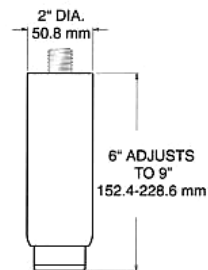

Ref.	Model n°	Mounting type
A	61751P360F7	3/4"-10 Flush Stud
B	61751FF60F7	3/4"-10 Thru Stud
C	61751P360W0	Plain Top for Welding

SPECIFICATIONS

Material/Finish : 16 GA (1,5 mm) 300 Series stainless steel / #4 Satin finish

Adjustment Range : 3" (76,2 mm)

Static Load Rating : 2000 lbs (907 Kg) per leg

OPTIONS

Three Styles of removal or welded mounting plates
 May be ordered packages in set of 4 for customer KD shipment





B.P 9168
 95075 CERGY PONTOISE CEDEX
 Tél : 01 34 48 34 10 / Fax : 01 34 21 80 40
 info@epcifrance.com
 www.epcifrance.com

PIEDS REGLABLES INOX
Séries 1751 – 1753 - 1758

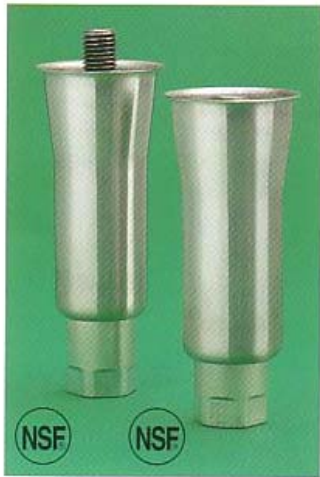

REF. A REF. B

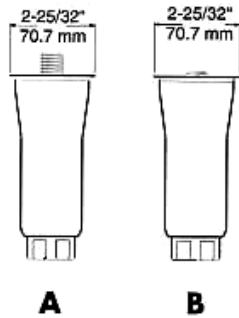

REF. C REF. D REF. E

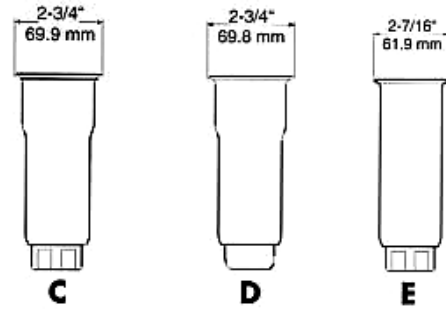

Ref.	Model n°	Description	Mounting Type	Toe type	Qty / Carton
A	61753HF60T7	Tapered Body	3/4" »-10 Thru	Hex	20
B	61753HF60F7	Tapered Body	3/4" »-10 Flush	Hex	20
C	61758HF60W0	Bell Body	For Welding	Hex	24
D	61758RF60W0	Bell Body	For Welding	Round	24
E	61751HF60W0	Straight Body	For Welding	Hex	24

SPECIFICATIONS

Material/Finish : 16 GA (1,5 mm) 300
 Series stainless steel / #4
 Satin finish

Static Load Rating : 2000 lbs (907 Kg) per leg

Adjustment Range : 1-3/4" (44,5 mm)

OPTIONS

Three Styles of removal or welded mounting plates
 May be ordered packages in set of 4 for customer

